

HYDE PARK MOULDINGS

CATALOGUE OF STANDARDS



FIRE SURROUNDS

HYDE PARK MOULDINGS, INC.
110 KENNEDY DRIVE
HAUPPAUGE, NY 11788
TEL: 631.PLASTER (631.752.7837)
INFO@HYDE-PARK.COM WWW.HYDE-PARK.COM

Draft 02-04-2011

french

The French fireplace design has changed extensively through the centuries. Our

well-rounded collection encompasses a range of styles and sizes to suit all tastes.



Château (FF-103)



Parisian

(FF-101)

Smooth Rococo curves and a center shell are typical characteristics of the Louis XV period. The Parisian works well in a den, apartment, or any area requiring a small yet elegant surround.

DIMENSIONS

A Outside Width:	57"
B Outside Height:	45" *
C Inside Width:	30 3/4"
D Inside Height:	31"-33"
Depth:	10 1/2"

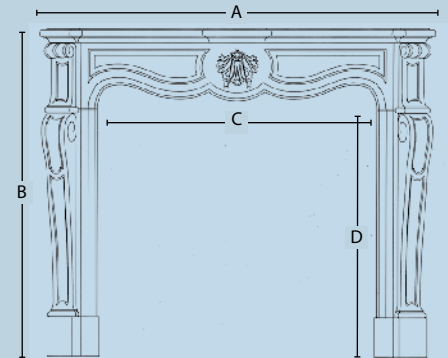

Normandie

(FF-102)

The Normandie is another smaller fireplace surround. If you are looking to add a highly detailed faux fireplace to an existing wall, then the Normandie's size makes it an excellent choice.

DIMENSIONS

A Outside Width:	49"
B Outside Height:	42"
C Inside Width:	30"
D Inside Height:	32"
Depth:	8 1/4"

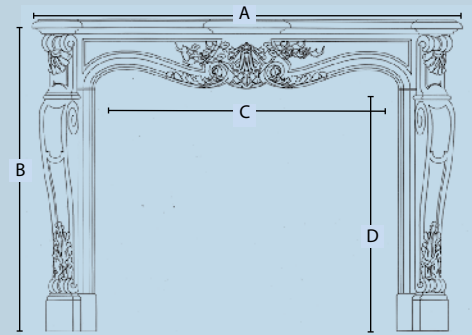

Château

(FF-103)

The Louis XVI-style Château fireplace surround combines acanthus brackets and laurels to create a timeless look with an authentic sense of elegance and delicacy.

DIMENSIONS

A Outside Width:	58"
B Outside Height:	44"
C Inside Width:	38 1/2"
D Inside Height:	33"
Depth:	9"

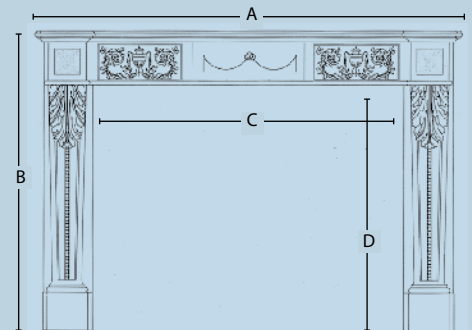

Renaissance

(FF-104)

Designed in Paris exclusively for the Republic collection, the Renaissance rounds out our French designs with its elegant floral frieze and delicate acanthus leaf scroll legs. The dimensions can be adjusted to match your specific firebox opening.

DIMENSIONS

A Outside Width:	66 1/4"
B Outside Height:	48 1/2" *
C Inside Width:	47 5/8"
Inside Height:	35 1/2" - 38 1/2"
Depth:	6 3/4"

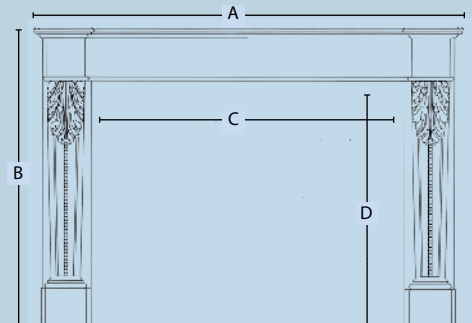

* A change to an inside dimension results in a corresponding change to the outside dimension
Draft 02-04-2011

bolections

Republic's Bolections range from traditional to modern. All Bolections are custom-made to fit the specific dimensions of your room. If you do not find the Bolection style you are looking for, ask us about a custom design.



Classic (BF-202)



Wave

(BF-201)

The simple Wave design is a perfect addition to the modern living room or den.

DIMENSIONS

Width: Adjustable
Height: Adjustable
A Depth: 4 1/2"

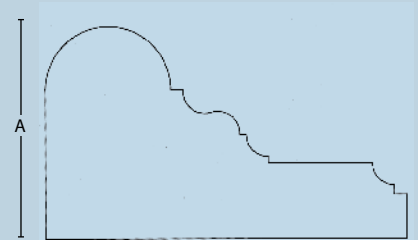

Classic

(BF-202)

The low relief Classic surround is perfect for creating a simple yet distinctive look and can be easily painted to match your home's décor.

DIMENSIONS

Width: Adjustable
Height: Adjustable
A Depth: 4 1/2"

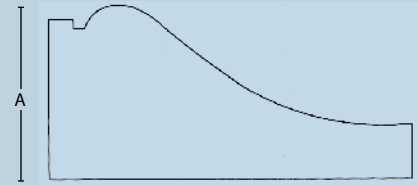

Step

(BF-203)

The modern Art Deco Step is cast in three custom-sized pieces, which can create both stone and painted smooth looks. Depending on your tastes, the Step can be made with either a paintable cast stone or our gypsum-based composite.* γ

* Note: The total shipping weight of the lightweight cast stone product is similar to that of the gypsum-based product, so there are virtually no additional shipping charges. Installation is just as simple as our other surrounds.

DIMENSIONS

Width: Adjustable
Height: Adjustable
Depth: 6"

All lengths are adjustable. Maximum outside width: 59 1/2"

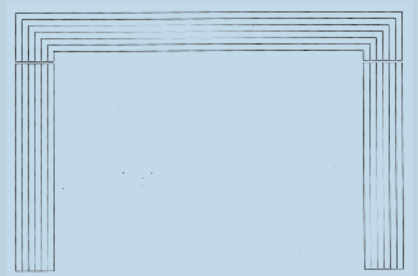

regency

The Regency Collection stands out with its highly detailed designs. The measurement of the opening can be customized to fit almost any length. After choosing a style, you may change the rosettes or add a plaque from those shown on the opposite page.



Ribbon-Tied Reeded Regency (RF-302)



Bulls Eye

(RF-301)

Simple, yet elegant, the classic linear 'Bulls Eye' design was popular during the Regency period.

DIMENSIONS

(For All Regency Models)

Width: Adjustable
Height: Adjustable
Depth: 8"

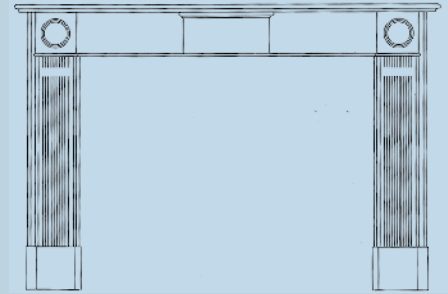

Ribbon-Tied

Reeded Regency (RF-302)

The classic reeded frame is shown here without a plaque and floral rosettes.



ARABESQUE FLORAL (RP-31)



Fluted Regency

(RF-303)

The Fluted Regency is shown here with a floral rosette and arabesque plaque.



LIONS (RP-32)



COAT OF ARMS (RP-33)



Reeded Regency

(RF-304)

The classic reeded frame is shown here without a plaque and floral rosettes.

Plaques

Since all our mantels are handcrafted, Republic can offer a truly custom product. All plaques shown on this page are completely interchangeable throughout the Regency Line. Simply tell your reseller which rosettes and/or plaque you prefer.

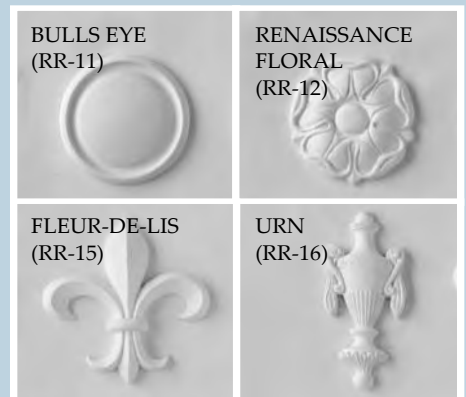

BULLS EYE (RR-11)

RENAISSANCE FLORAL (RR-12)

FLEUR-DE-LIS (RR-15)

URN (RR-16)

american

The one truly American-style fireplace surround was originally created in the early 1800s. Curved arches and ornate carvings are typical of Northern as well as Southern Colonial fashions. The American is an excellent complement to any arched fireplace opening or insert.



Lexington (AF-405)



HYDE PARK MOULDINGS

Architectural and Ornamental Plaster
est. 1962

Fire Surrounds

www.hyde-park.com



Lexington

(AF-401)

1 Dimensions

With floral drops and reveals, the Lexington is one of our more exquisite American fireplace surrounds.

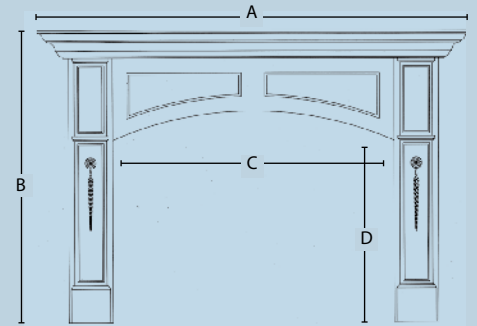

Jefferson

(AF-402)

1 Dimensions

With a similar look to that of the Williamsburg, the Jefferson has fluted columns and grape leaf reveals.

1

DIMENSIONS

A Outside Width:	74" *
B Outside Height:	50" *
C Inside Width:	43 3/4" - 48 1/4"
D Inside Height:	31" - 40"
Depth:	8"



Charleston

(AF-403)

1 Dimensions

As with the Concord, the Charleston's classic ogee molding and raised panel relief are typical of the American Colonial fireplace surround.

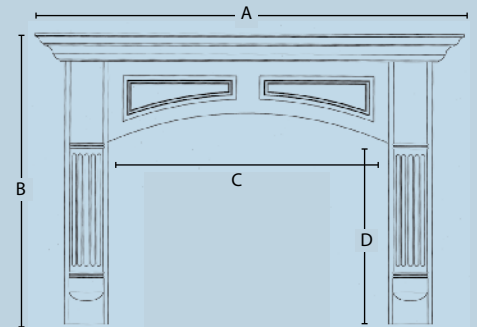

Concord

(AF-405)

2 Dimensions

One of our more popular American designs, the Concord can be adjusted to fit most fireplace openings.

2

DIMENSIONS

A Outside Width:	74" *
B Outside Height:	50" *
C Inside Width:	43 3/4" - 48 1/4"
D Inside Height:	31" - 40"
Depth:	7"

* A change to an inside dimension results in a corresponding change to the outside dimension

tudor

The Tudor's larger and more detailed mantel, with meticulous carvings, is reminiscent of the High-Medieval design common in Great Britain during the 15th and 16th centuries. As with most Republic surrounds, the measurements of the Tudor can be adjusted to meet your home's dimensions.



Elizabethan (GF-503)



Stuart

(GF-501)

1 Dimensions

As our most highly detailed Tudor design, the Stuart's floral coat of arms and acanthus leaf pointed arches will become a timeless conversation piece in your home.

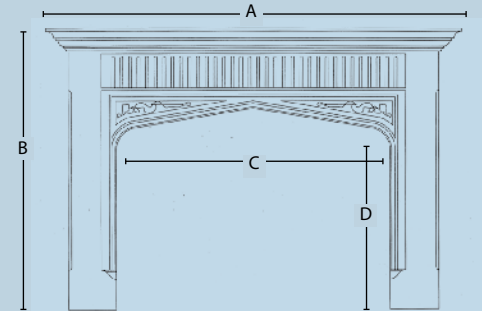

Jacobean

(GF-502)

1 Dimensions

The coat of arms is centered in a floral frieze with a pair of classic pointed arches.

1

DIMENSIONS

A Outside Width:	72 1/4" *
B Outside Height:	67 3/4" *
C Inside Width:	44" - 48"
D Inside Height:	32" - 42"
Depth:	9 1/2"



Elizabethan

(GF-503)

1 Dimensions

The Elizabethan has a cathedral fluted frieze and floral pointed arches.

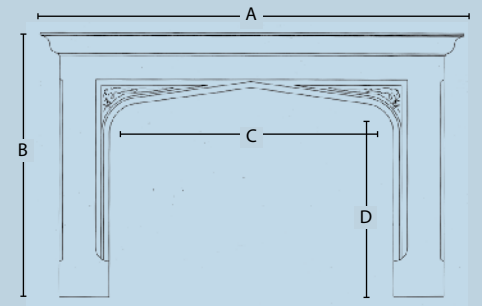

Wellesley

(GF-505)

2 Dimensions

The Wellesley has a pair of classic Tudor pointed arches and an early Gothic mantel.

2

DIMENSIONS

A Outside Width:	72 1/4" *
B Outside Height:	70 1/2" *
C Inside Width:	44" - 48"
D Inside Height:	32" - 42"
Depth:	9 1/2"

* A change to an inside dimension results in a corresponding change to the outside dimension

victorian

Our Victorian collection of fireplace surrounds is modeled from historically significant pieces found throughout Great Britain, France, and Italy. The proportions of the embellishments, as well as the surrounds themselves, are all historically accurate.



Georgian (VF-601)



HYDE PARK MOULDINGS

Architectural and Ornamental Plaster
est. 1962

Fire Surrounds

www.hyde-park.com



Georgian

(VF-601)

The imposing fluted Doric columns and broad mantel are in the late Georgian style.

DIMENSIONS

A Outside Width:	66 1/4" *
B Outside Height:	50" *
C Inside Width:	37" - 47 1/2"
D Inside Height:	36" - 40"
Depth:	6 3/4"

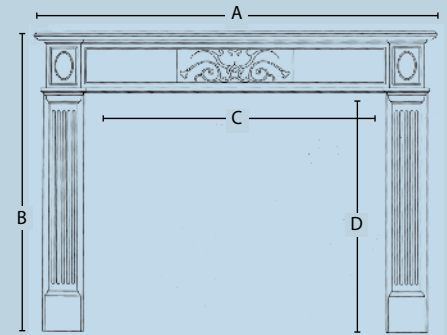

Oxford

(VF-602)

This classic 19th century Victorian design is available with or without floral swags or drops on the legs.

DIMENSIONS

A Outside Width:	66 1/4" *
B Outside Height:	52" *
C Inside Width:	37" - 47 1/2"
D Inside Height:	36" - 42"
Depth:	6 3/4"

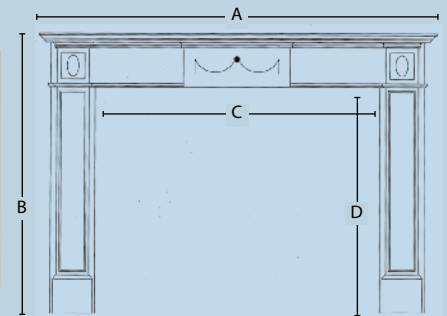

The Oxford is also available with a plain leg or the ornate drop (VD-51) shown right.



Acanthus

(VF-603)

The beautifully sculpted floral scroll legs of the Acanthus can be enhanced with any rosette, frieze or plaque shown on this page.

DIMENSIONS

A Outside Width:	66 1/4" *
B Outside Height:	48 1/2" *
C Inside Width:	37" - 47 1/2"
D Inside Height:	35 1/2" - 38 1/2"
Depth:	6 3/4"

* A change to an inside dimension results in a corresponding change to the outside dimension

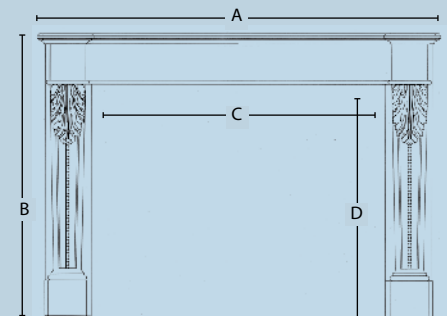

ROSETTE (VP-41)



FLORAL DROP (VP-42)



RIBBON-TIED FLOWER (VP-43)



GRAPE LEAF (VP-44)



Plaques & Rosettes

All plaques and rosettes shown on this page can be interchanged throughout the Victorian collection. The designs shown in this section are merely suggested ideas. Feel free to create your own unique fireplace surround.

FEMALE FIGURES (VR-22)



OYSTER (VR-25)



FRENCH FLO-
RAL (VR-26)

